

Part I: Basics

Please introduce the following laws or theorems. *Each variable in the formulas must be explained. Putting formulas without explanations will gain no point.*

1. Coulomb's Law (10 points)
2. Ampere's Law (10 points)
3. Biot-Savart Law (10 points)
4. Gauss' Law (10 points)
5. Faraday's Law (10 points)

Part II: Calculation and Elaboration

6. A uniformly charged disk has radius R and surface charge density σ (shown in Fig. 1). Find (a) the electric potential at a point P along the perpendicular central axis of the disk (5 points), and (b) prove that the x component of the electric field at a point P along the perpendicular central axis of the disk is

$$2\pi k_e \sigma \left[1 - \frac{x}{(R^2 + x^2)^{1/2}} \right]. \text{ (5 points)}$$

Note that (b) must be solved by differentiating the result in (a) and we set the potential at infinity to be zeros.

7. Prove that a capacitance of two parallel plates shown in Fig. 2 is $\epsilon_0 A / d$ (10 points)
8. Please prove that the field inside an ideal solenoid (Fig. 3) is $B = \mu_0 n I$; where n is the number of turns per unit length. (5 points). Please explain what conditions for a solenoid to be ideal are. (5 points)
9. What is electrostatic equilibrium of a conductor? (5 points) Explain why the electric field is zero everywhere inside the conductor when the conductor is in electrostatic equilibrium whether the conductor is solid or hollow. (5 points)
10. Explain why charge resides on conductor's surface when the conductor is isolated and carries a charge in electrostatic equilibrium. (10 points)

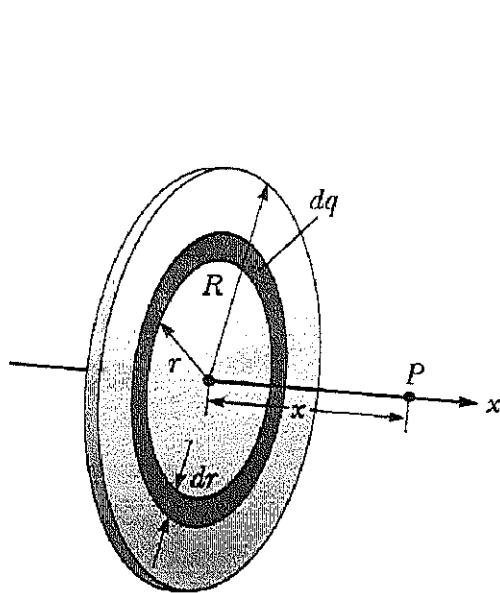

Fig. 1

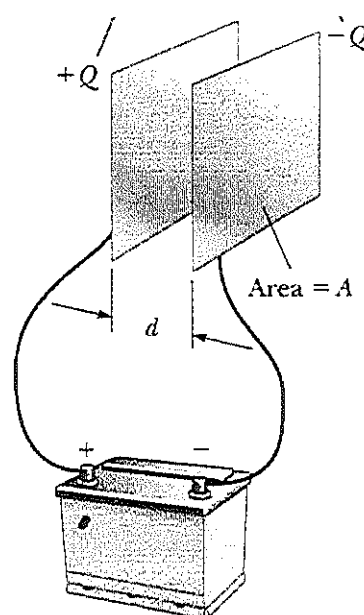

Fig. 2

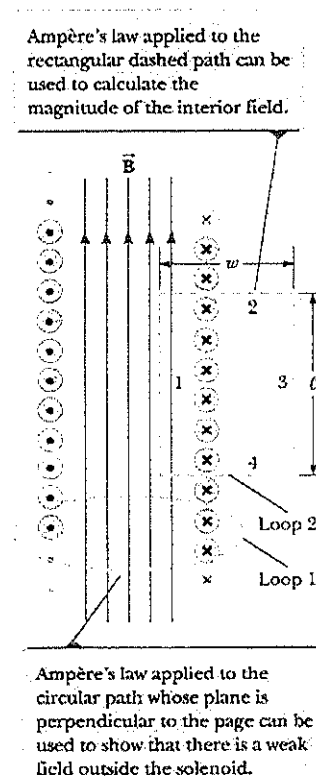

Fig. 3