

國立臺北大學 104 學年度學士班暨進修學士班轉學生招生考試試題

系 別：通訊工程學系學士班 2 年級
 科 目：物理學

考試時間：80 分鐘

第 1 頁 共 2 頁

可 不可 使用計算機

1. (2% for each blank, 12% in total, 本題計算過程不計分)

Suppose two infinite planes of charge are parallel to each other (Fig. 1), one positively charged and the other negatively charged. Both planes have the same charge density σ . The direction and the magnitude of electric field at point P1 (to the left of the positively charged plane) are _____ (1a) _____ and _____ (1b) _____, respectively. The direction and the magnitude of electric field at point P3 (to the right of the negatively charged plane) are _____ (1c) _____ and _____ (1d) _____, respectively. The direction and the magnitude of electric field at point P2 (between the two planes) are _____ (1e) _____ and _____ (1f) _____, respectively.

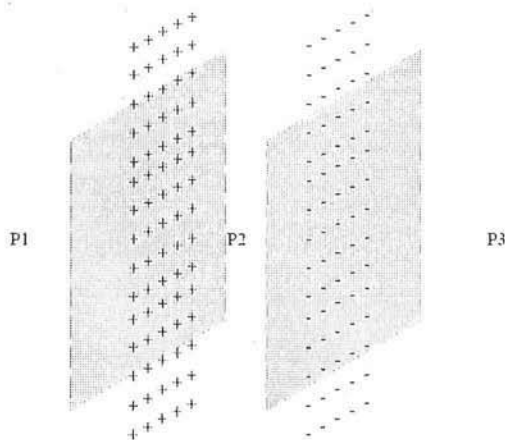

Fig. 1

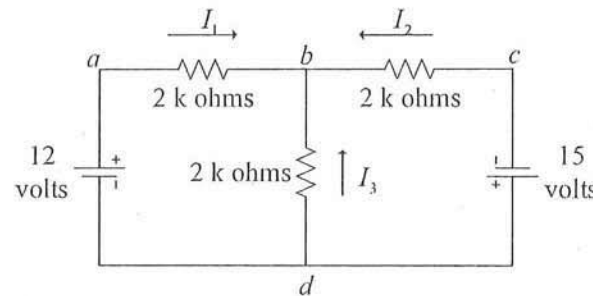

Fig. 2

3. (3 % for each blank, 6% in total)

Please briefly explain (a) Faraday's Law of Induction: _____ (3a) _____, and (b) Lenz's Law: _____ (3b) _____.

4. (3 %) What is the origin of the magnetic field? Your explanation: _____ (4) _____

5. (5 % , 本題計算過程須計分) Find an equivalent resistor $Z =$ _____ (5) _____ (Fig. 3 lower) for the infinite blocks of resistors (Fig. 3 upper).

6. (7 % , 本題計算過程須計分) Two spherical conductors of radii r_1 and r_2 are separated by a distance much greater than the radius of either sphere. The spheres are connected by a conducting wire as shown in Fig. 4. The charges on the spheres in equilibrium are q_1 and q_2 , respectively, and they are uniformly charged. Find the ratio of the magnitude of the electric field at the surface of the sphere 1 to the one of the sphere 2 is _____ (6a) (3%) _____. Please use the meaning of the ratio to explain the principle of a lightning rod (避雷針). Your explanation: _____ (6b) (4%) _____

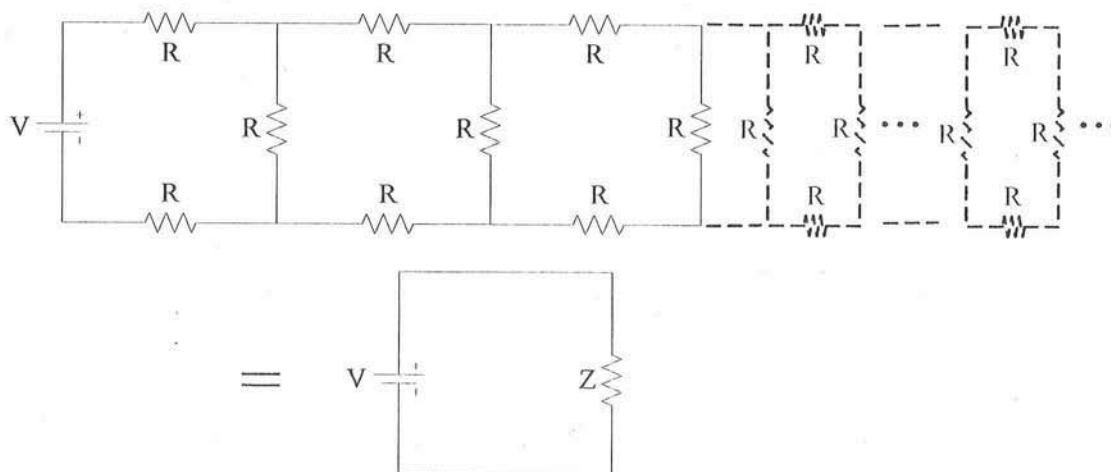

Fig. 3

國立臺北大學 104 學年度學士班暨進修學士班轉學生招生考試試題

系 別：通訊工程學系學士班 2 年級
 科 目：物理學

考試時間：80 分鐘

第 2 頁 共 2 頁

可 不可 使用計算機

7. (5% , 本題計算過程須計分) A disk of radius R has a uniform surface charge density σ (Fig. 5). Prove that magnitude of the electric field at a point P is $E = 2\pi k_e \sigma \left[1 - \frac{x}{(R^2 + x^2)^{1/2}} \right]$. Note that P lies along the central perpendicular axis of the disk and a distance x from the center of the disk. Your proof: _____ (7)

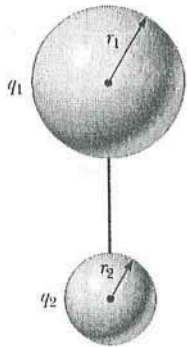

Fig. 4

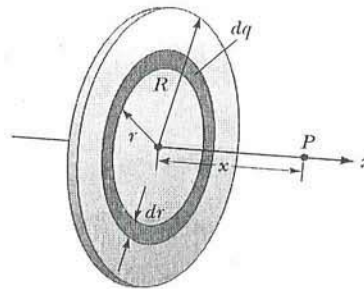

Fig. 5

8. (2%) What is drift speed in a conductor? Your explanation: _____ (8)
9. (4%) In normal cases, drift speed in a conductor is very slow. But, why a light bulb can be turned on immediately after switch is on? Your explanation: _____ (9)
10. (2%) What is the back EMF? _____ (10)
11. (8%) Assume a uniformly wound solenoid having N turns and length ℓ , and ℓ is much greater than the radius of the solenoid, prove: (a) the flux through each turn of area A is $\Phi_B = \mu_0 N I A / \ell$, and (b) the inductance is $L = \mu_0 N^2 A / \ell$. Your proofs for (a): _____ (11a) (4%) and for (b) _____ (11b) (4%)
12. (4%) Please explain the Hall effect. Your explanation: _____ (12)
13. (4%) Please illustrate the experiment for defining the unit for current by Ampere. Your illustration: _____ (13)
14. (5% , 本題計算過程須計分) Fig. 6 shows a very simple RL circuit with a resistor R ohms, an inductor L henries, and a battery of V volts. Prove that the current $I(t)$ after switch is on ($t = 0^+$) is $I(t) = (V/R)(1 - e^{-t/(L/R)})$. Your proof: _____ (14)

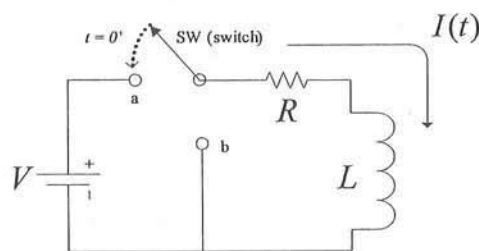

Fig. 6

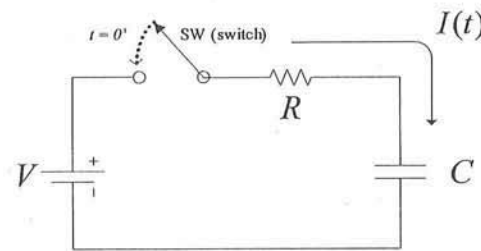

Fig. 7

15. (5% , 本題計算過程須計分) Fig. 7 shows a very simple RC circuit with a resistor R ohms, a capacitor C farads, and a battery of V volts. Prove that the current $I(t)$ after switch is on ($t = 0^+$) is $I(t) = (V/R)e^{-t/(RC)}$. Your proof: _____ (15)
16. (12% , 本題計算過程須計分) Concept of Impedance
- (a) Prove that the impedance for an inductor (L farads) is $Z_L = j\omega L$. Your proof: _____ (16a) (4%)
- (b) Why low-frequency sinusoidal current is easier to pass through a capacitor? Your explanation: _____ (16b) (4%)
- (c) What is physical meaning of the term j in Z_L ? Your explanation: _____ (16c) (4%)
17. (4%) What are definitions for alternating current (AC) and direct current (DC)? Your explanation: _____ (17)
18. (6%) Explain why electric field is zero everywhere inside a conductor and charge resides on the conductor's surface when the conductor is in electrostatic equilibrium whether the conductor is solid or hollow. Your explanation: _____ (18)